



NO: RD-157S0183

DATE: 2005/09/15 I (REV:A1)

10/100 BASE-T SMT TRANSFOR

MODEL NO.: HA-019

FEATURE:

RoHS Compliant

RoHS peak solder rating 260

Designed to meet IR requirement

Specifications @ 25

Operating temp. : -40 ~ +85

OCL : 350uH Min @100Khz , 100mV 8mA

Part Number	Turns Ratio (±3%)	OCL (uH MIN)	LL (uH MAX)	Cww (pF MAX)	DCR (ΩMAX)	Insertion Loss (dB MAX)	Cross Talk (dB MIN)	Return Loss (dB)	Common Mode Rejection (dB MIN)	HITOP HIPOT (VAC)
HA-019	1CT::1CT	350	0.40	30	1.5	1 to 100MHz	0.11-100 MHz	40 MHz	1 -100 MHz	1500
						1.1	35	15.5	-35	

SCHEMATICS:

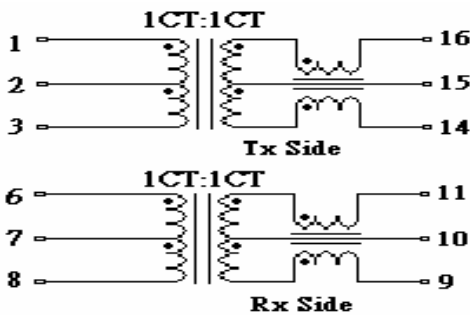

DIMENSION: mm

TOLERANCE: ±0.25

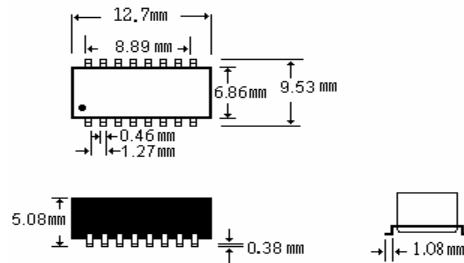

Packing :

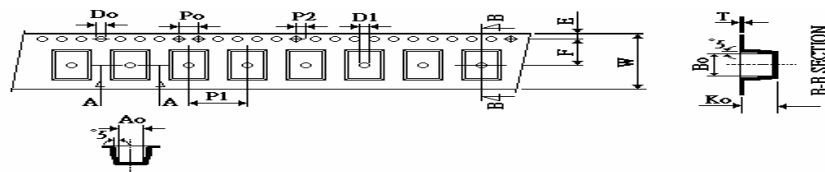

DIMENSION	W	P1	P0	E	F	AO	BO	Aot
SPEC.	24.0	16.0	4.0	1.75	11.5	10.0	13.2	0.08
	+/- 0.30	0.10	0.10	0.10	0.10	0.10	0.10	(MIN)
DIMENSION	K0	P2	D0	D1	10P0	T	K1	Bot
SPEC.	6.80	2.0	1.55	1.5	40.0	0.40	6.15	0.08
	+/- 0.10	0.10	0.05	(MIN)	0.20	0.10	0.10	(MIN)

Tape & reel.....600/reel
Tube.....39/tub

MODEL NO.: HA-019

Profile of IR Reflow (Lead Free)

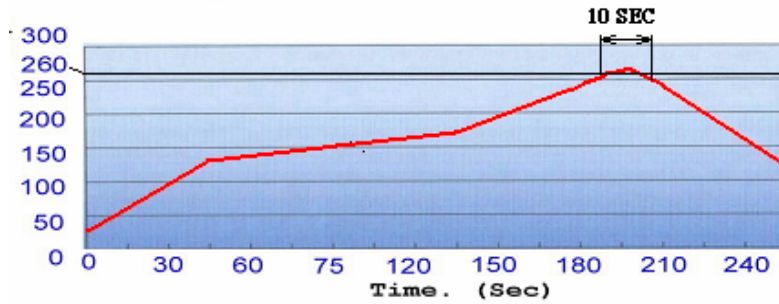

PACKING

1. Tape & Reel : 600pcs / Reel , 3000pcs / Carton
2. Dry Pack : 1pcs
Product Description:(5g Silica Gel Desiccant)
PH: 4-8
Package Materials: Paper(Length 6.5±1cm , Width 5±1cm)
3. Reel Packed By Vacuum
4. Seal Per Jedec

