

10/100 PC CARD MAGNETIC MODULE

MODEL NO.: HC-027

FEATURE:

RoHS Compliant

Do not use material and use that the prohibition that SS-00259 stipulates

RoHS peak solder rating 260°C/ 3~5Sec

Designed to meet IR requirement

Meets IEEE802.3 Baseline Wander Compensation specification

Specifications @ 25°C

Operating temp : 0°C to +80°C

OCL : 350uH MIN.(100KHz,100mV)

Cw/w : 25 pF Max. (100KHz,100mV)

DCR (1-2 & 5-6 PIN) : 1.0 Ω Max

DCR (7-8 & 11-12 PIN) : 1.5 Ω Max.

HIPOT(VAC) : 1500 (60s / 10mA) CHIP SIDE:(1-2-3)&(4-5-6) Short , LAN SIDE (7-8-9)&(10-11-12) Short

Part Number	Turns Ratio (±5%)	Insertion Loss (dB MIN)	Return Loss (dB MIN)		Common Mode Rejection Ratio (dB MIN .)		Cross Talk (dB MIN)	
			1~40 MHz	40~100 MHz	2 MHz	30-200 MHz	1 MHz	10~100 MHz
HC-027	TX/RX	0.1~125 MHz	-16	-10+20*log ₁₀ (f/80MHz)	-42	-15+20*log ₁₀ (f/200 MHz)	-50	-50+22*log ₁₀ (f/10MHz)
	1CT:1CT	-1.1	-16	-10+20*log ₁₀ (f/80MHz)	-42	-15+20*log ₁₀ (f/200 MHz)	-50	-50+22*log ₁₀ (f/10MHz)

SCHEMATIC:

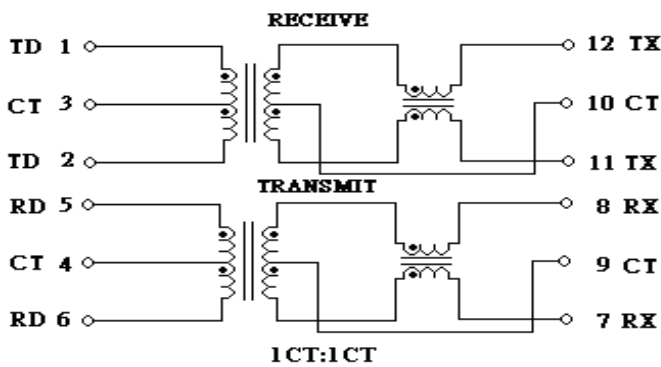

DIMENSION: mm

TOLERANCE: (±0.25)

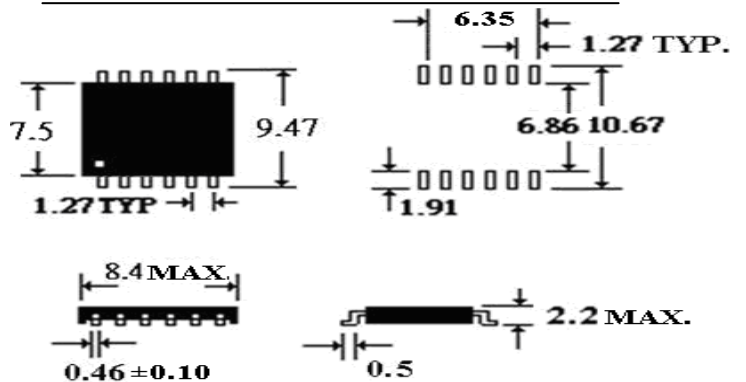

Packing:

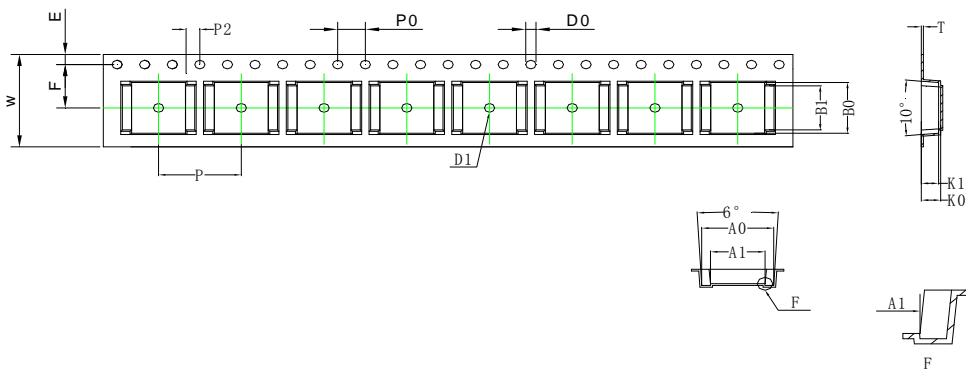

D ₀	P ₀	P ₂
1.5 ^{+0.10} _{-0.00}	4.0 ^{+0.10} _{-0.10}	2.0 ^{+0.10} _{-0.10}

ITEM	W	A ₀	A ₁	B ₀	B ₁	K ₀	K ₁	E	D ₁	P	F	T
DIM	16.0 ^{+0.30} _{-0.30}	10.45 ^{+0.10} _{-0.10}	7.90 ^{+0.10} _{-0.10}	8.80 ^{+0.10} _{-0.10}	7.60 ^{+0.10} _{-0.10}	2.80 ^{+0.10} _{-0.10}	2.50 ^{+0.10} _{-0.10}	1.75 ^{+0.10} _{-0.10}	1.50 ^{+0.10} _{-0.00}	12.0 ^{+0.10} _{-0.10}	7.50 ^{+0.10} _{-0.10}	0.30 ^{+0.05} _{-0.05}

MODEL NO.: HC-027

**Solder Reflow profile for Lead-Free packages.
Package Peak Reflow Temperatures**

Classification Reflow Profiles

Profile Feature	Lead-Free Assembly	
Average ramp-up rate(T_L to T_P)	3°C / Second Max.	
Preheat Temperature Min.(T_s min.) Temperature Max.(T_s max.) Time (min to max) (t_s)	150 °C 200 °C 60-180 sec	
T_s max. to T_L Ramp-up Rate	3°C / Second Max.	
Time maintained above Temperature (T_L) Time (t_L)	217 °C 60-150 sec	
Peak Tempature (T_p) Time within 5 °C of actual peak Temp.	260 +0 / -5 °C 3 to 5 Sec	250 +0 / -5 °C 20 to 40 Sec
Ramp-down	6°C / Second Max.	
Time 25 °C to Peak Temperature	8 minutes Max.	

Profile

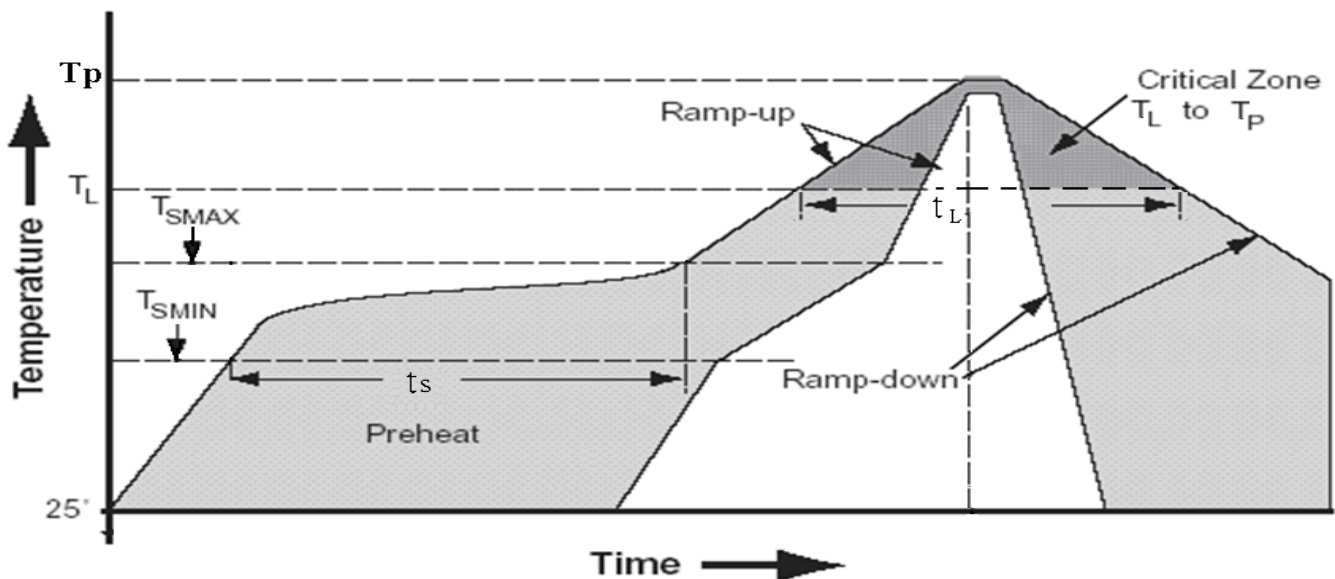

MODEL NO. : HC-027

PACKING

1. Tape & Reel : 1400pcs / Reel , 7000pcs / Carton
2. Dry Pack : 1pcs
Product Description:(5g Silica Gel Desiccant)
PH: 4-8
Package Materials: Paper(Length 6.5±1cm , Width 5±1cm)
3. Reel Packed By Vocumm
Reel (Diameter & Height): 33cm*2.08cm
4. Seal Per Jedec

