



NO:RD-HD-SD045  
DATE: 2005/09/20- I (REV:A1)

# 10/100 PC CARD LAN MAGNETICS SOLUTIONS

## MODEL NO.: HD-045

### FEATURE:

RoHS Compliant

RoHS peak solder rating 260

Designed to meet IR requirement

Specifications : AT 25

Operating temp. : -40 ~ +85

OCL : 350uH Min @100Khz , 100mV 8mA

DCR 1/2 WINDING: 0.65Ω(MAX)

Part Number	Turns Ratio ( ±2% )	Insertion Loss (dB MAX)	Return loss (dB MIN)			Cross talk (dB MIN)		Common Mode Rejection (dB MIN)		Hi pot (Vrms)
		1MHz~100MHz	1~30	30~60	60~80MHz	1MHz	10~100MHz	2MHz	30~200MHz	
HD-045	1CT:1CT	-1.2	-16	-10+20log10	-10	-50	-15+22log10	-42	-15+20log10	1500

### SCHEMATICS:

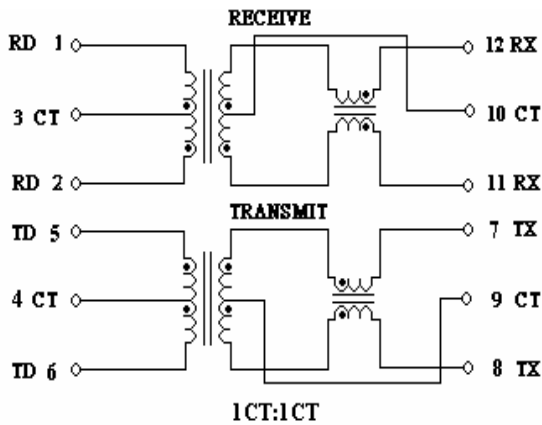

### DIMENSION: mm

TOLERANCE: ±0.25

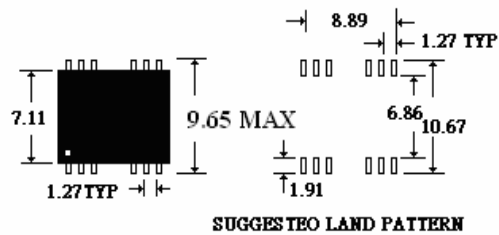

### Packing :

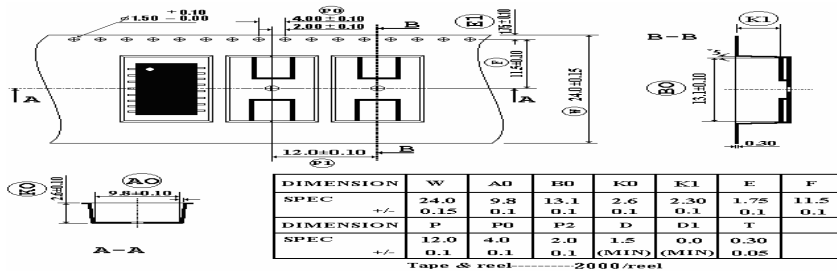

## MODEL NO.: HD-045

### Profile of IR Reflow (Lead Free)

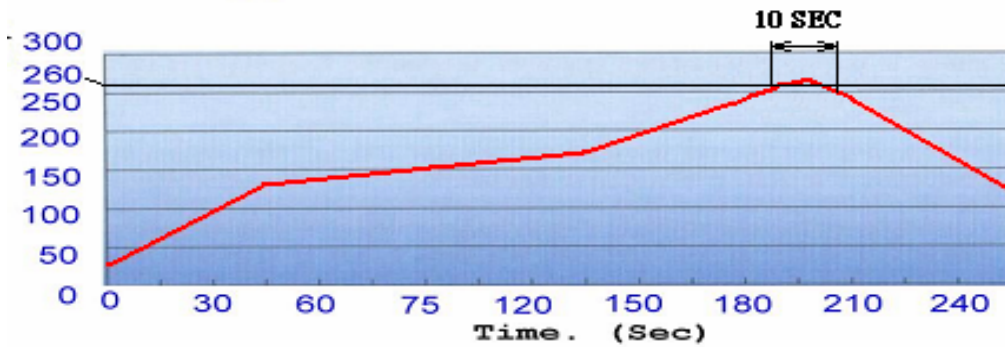

PACKING	
1.	Tape & Reel: 2000 pcs / Reel, 10000 pcs / Carton
2.	Dry Pack: 1 pc. Product Description: 5g Silica Gel Desiccant PH: 4-8 Package Materials: Paper (Length 6.5±1cm, Width 5±1cm)
3.	Reel: Vacuum Packed
4.	Seal as per JEDEC

