



NO:RD-LF-H80P  
DATE: 2005/09/20-I(REV:A2)

# 10/100 PC CARD LAN MAGNETICS SOLUTIONS

## MODEL NO.: HD-051

### FEATURE:

RoHS Compliant

RoHS peak solder rating 260

Designed to meet IR requirement

Specifications : AT 25

Operating temp. : -40 ~ +85

OCL : 350uH Min @100Khz , 100mV 8mA

Part Number	Turns Ratio (±2%)	Insertion Loss (dB MAX)	Return loss (dB MIN)			Cross talk (dB MIN)	Common Mode Rejection (dB MIN)		Hi pot 1,2,3 to 16,15,14 6,7,8 to 9,10,11
			1MHz~100MHz	30MHz	60MHz		80MHz	30MHz	
HD-051	1CT:1CT 1CT:1CT	-0.9	-16	-12	-11	-38	-40	-40	1500

### SCHEMATICS:

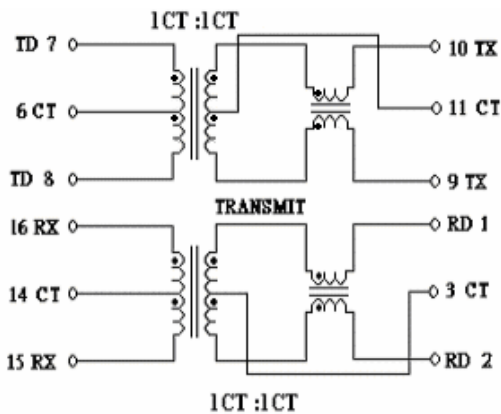

### DIMENSION: mm

TOLERANCE: ±0.25

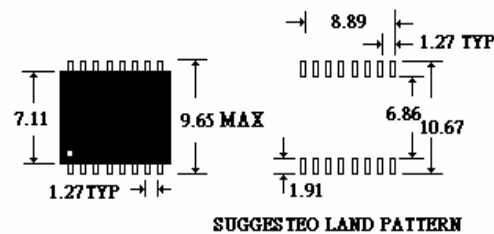

SUGGESTED LAND PATTERN



NOTE : COPLANARITY IS

### Packing :

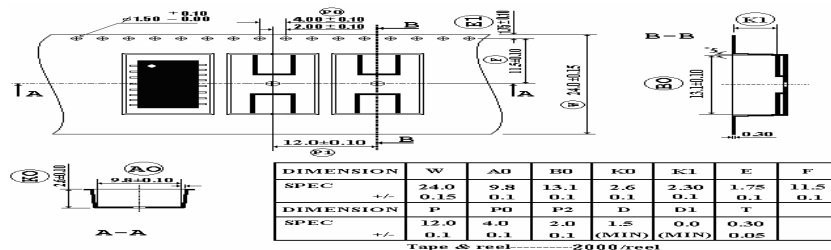

## MODEL NO.: HD-051

### Profile of IR Reflow (Lead Free)

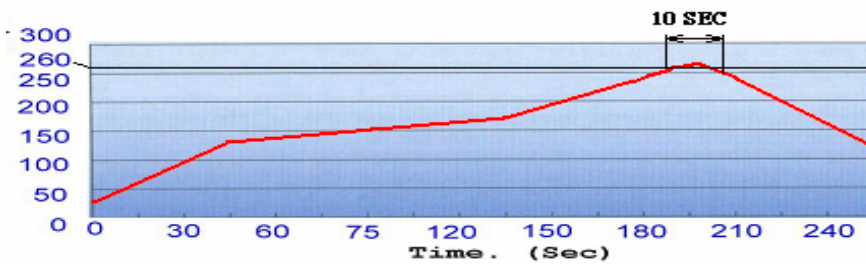

### PACKING

1. Tape & Reel: 2000 pcs / Reel, 10000 pcs / Carton
2. Dry Pack: 1 pc.  
 Product Description: 5g Silica Gel Desiccant  
 PH: 4-8  
 Package Materials: Paper (Length 6.5±1cm, Width 5±1cm)
3. Reel: Vacuum Packed
4. Seal as per JEDEC

