



NO:RD-HF-SD012D
 DATE: 2005/9/20 I (REV:A1)

10/100 BASE-T DUAL DIP TRANSFORMER TP/PMD AND 155MBPS ATM MODEL NO.: HF-012D

FEATURE:

RoHS Compliant

Specifications : AT 25

Operating temp. : -40 ~ +85

OCL (uH MIN) 350uH Min @100Khz , 100mV 8mA

Cww (pF MAX) 20

LL (uH MAX) 0.30

Part Number	Transformer Turns ratio ($\pm 2\%$)		Insertion Loss (dB TYP) 1-100MHz	Crosstalk (dB TYP)				Return loss 5 to 100 Mhz (dB MIN)		Common Mode Rejection (dB MIN)		Hipot VAC
	Receive	Transmit		1MHz	30MHz	60MHz	100MHz	1-60MHz	60-100MHz	1-60	60-100	
HF-012D	1:1	1CT:1CT	-0.5	-65	-55	-45	-35	-15	-12	-40	-30	1500

SCHEMATICS:

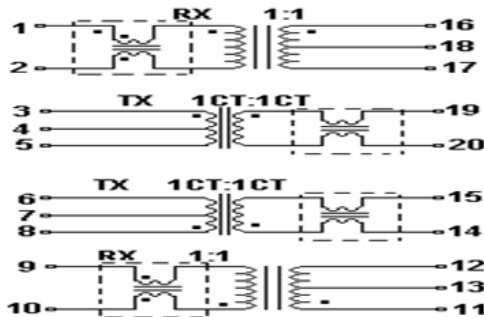

DIMENSION: mm

TOLERANCE: $\pm 0.25(0.010)$

