



NO:RD-LF-H20P  
Date:2005/9/20-I (REV:A1)

**10/100 BASE-T DUAL DIP FOR AUTO TRANSFORMER  
TP/PMD AND 155MBPS ATM  
MODEL NO.: HF-021D**

**FEATURE:**

**RoHS Compliant**

**Specifications : AT 25**

**Operating temp. : -40 ~ +85**

**OCL (uH MIN) 350uH Min @100Khz , 100mV 8mA**

**Cww (pF TYP) 50**

**LL (uH MAX) 0.4**

**DCR(ΩMAX) 0.9**

Part Number	Transformer Turns ratio (±3 %)	Insertion Loss (dBMAX) 0.1-100MHz	Crosstalk (dB MIN) 0.1-100MHz	Return loss (dB MIN)			Common (dB ) 0.1-100MHz	Hipot VAC
				1-30MHz	40-50MHz	60-80MHz		
HF-021D	RX.1CT:1CT TX.1CT:1CT	-1.0	-32	-18	-15	-12	-40	1500

**SCHEMATICS:**

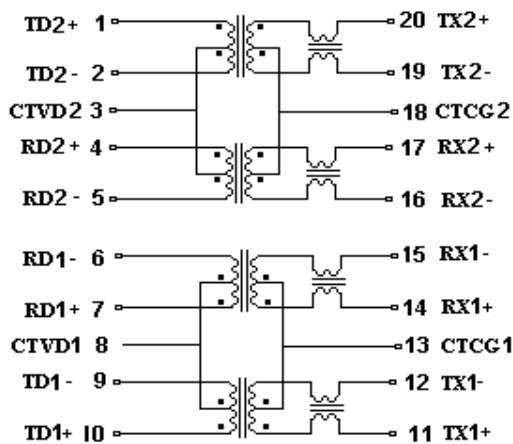

**DIMENSION: mm**

TOLERANCE: ±0.25

