



NO:RD-HH- S558-5500-12 / XFMRS : XFVOIP-02  
 Date:2003/04/10-J(REV:0/1)

**10/100/ BASE VOICE OVER IP MAGNETICS**

**MODEL NO.: HH-007**

**FEATURES:**

**RoHS Compliant**

**RoHS peak solder rating 260**

**Designed to meet IR requirement**

**SPECIFICATIONS: AT 25**

**OPERATION TEMP: 0 TO +70**

Part Number	Turns Ratio ( ±5% )		OCL uH, 8mA MIN )	LL (uH MAX)	Cww pF (MAX)	DCR Ω (MAX)	Insertion Loss ( dB MIN )	Cross Talk ( dB MIN )		Return Loss ( dB MIN )		Common Mode Rejection ( dB MIN )	HIPO T ( VAC )
	TX	RX											
HH-007	TX	RX	350	0.25	25	1.0	0.1 to 100 MHz	1 to 30 MHz	60 to 100 MHz	2 to 30 MHz	60 to 80 MHz	0.1 to 100 MHz	1500
	1CT: 1CT	1CT: 1CT					-1.5	-60	-45	-16	-10	-45	

**SCHEMATICS:**

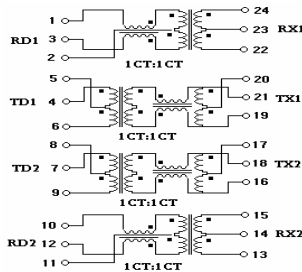

**DIMENSION:**

TOLERANCE: mm(±0.25)

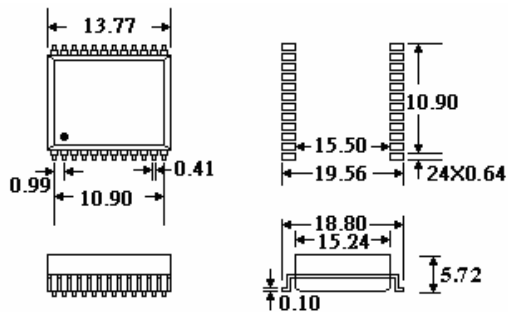

**Packing:**

ITEM	W	A0	B0	K0	K1	P	E	F	D	D1	P0	P2
DIM	24 <sup>+0.3</sup> <sub>-0.3</sub>	15.3 <sup>+0.1</sup> <sub>-0.1</sub>	14.1 <sup>+0.1</sup> <sub>-0.1</sub>	6.9 <sup>+0.1</sup> <sub>-0.1</sub>	6.4 <sup>+0.1</sup> <sub>-0.1</sub>	20 <sup>+0.1</sup> <sub>-0.1</sub>	1.75 <sup>+0.1</sup> <sub>-0.1</sub>	11.5 <sup>+0.1</sup> <sub>-0.1</sub>	1.5 <sup>+0.1</sup> <sub>-0.1</sub>	0.0 <sup>+0.25</sup> <sub>-0.0</sub>	4.0 <sup>+0.1</sup> <sub>-0.1</sub>	2.0 <sup>+0.1</sup> <sub>-0.1</sub>

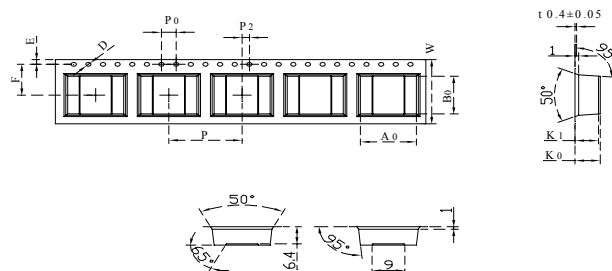

## MODEL NO.: HH-007 Profile of IR Reflow (Lead Free)

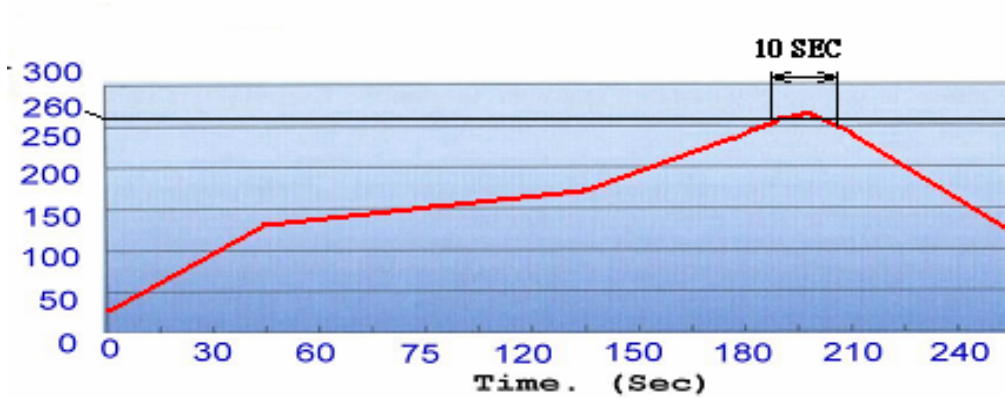

### PACKING

1. Tape & Reel : 400pcs / Reel , 2000pcs / Carton
2. Dry Pack : 1pcs  
Product Description:(5g Silica Gel Desiccant)  
PH: 4-8  
Package Materials: Paper(Length 6.5±1cm , Width 5±1cm)
3. Reel Packed By Vocumm
4. Seal Per Jedec

