



NO:RD-Pulse:H5019
 DATA:2005/09/13 I (REV:A1)

1000 BASE-T MAGNETICS MODULES

MODEL NO.: IH-009

FEATURE:

10/100/1000 Mbps Ethernet applications
 DESIGNED TO MEET IR REQUIREMENT

RoHS Compliant

RoHS peak soldering rating: 260°C

SPECIFICATIONS: AT 25

OPERATION TEMP : -40 ~ +85

OCL: 350 MIN @ 8mA (100KHz, 100mV)

Hi pot (Vrms) : 1500

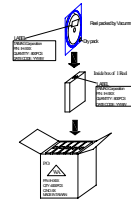

Part Number	Insertion Loss (dB MAX)	Return Loss (dB Min) 100Ω±15%					Differential to Common Mode Rejection (dB MIN)				Cross talk(TX-RX) (dB MIN)			
		1~100	1-40	50	60	60-80	100 MHz	2	30	60	100 MHz	1	30	60
IH-009	-1.0	-18	-14	-12.5	-12	-10	-50	-43	-37	-33	-50	-45	-40	-35

SCHEMATICS:

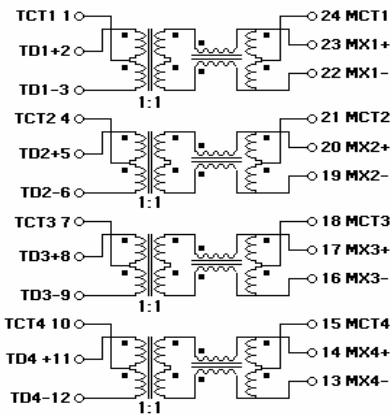

DIMENSION: mm TOLERANCE:±0.25

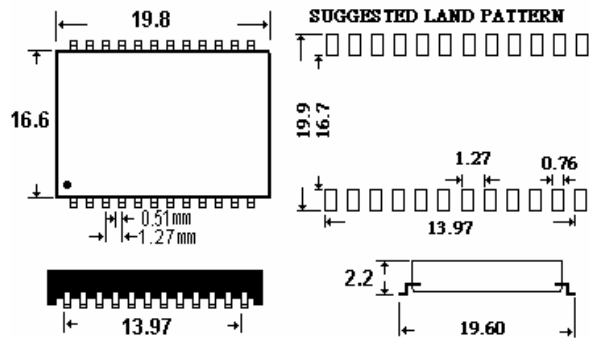

Packing :

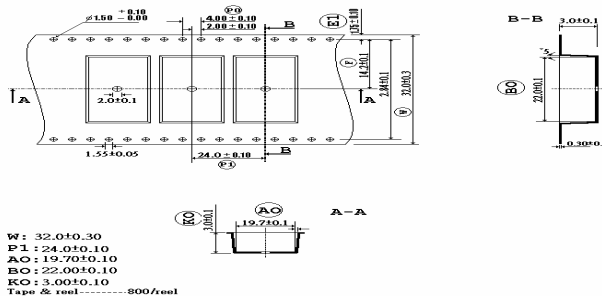

MODEL NO.: IH-009 Profile of IR Reflow (Lead Free)

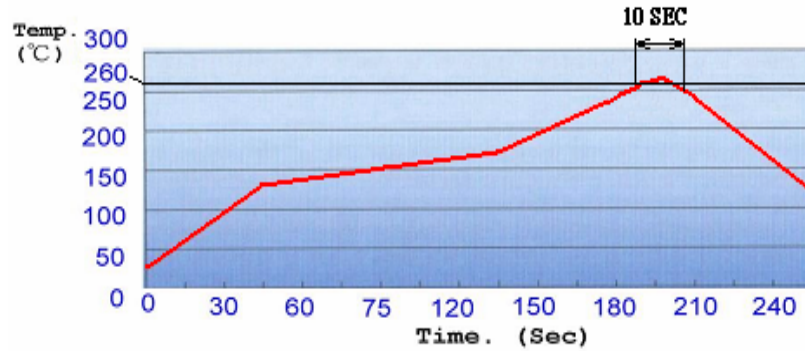

PACKING

1. Tape & Reel : 800pcs / Reel , 4000pcs / Carton
2. Dry Pack : 1pcs
Product Description:(5g Silica Gel Desiccant)
PH: 4-8
Package Materials: Paper(Length 6.5±1cm , Width 5±1cm)
3. Reel Packed By Vacuum
4. Seal Per Jedec

