

10/100 BASE FILTER WITH CONNECTOR MODEL NO. : RJ-053TA1

Features :

RoHS Compliant

Fully shielded magnetics protect data from internally generated digital noise

Reduces the overall length of the signal path for improved common mode performance

Implements full common mode termination scheme with used and unused twisted pairs

Meets IEEE802.3 Baseline Wander Compensation specification

Integrates high voltage capacitor to chassis ground

Supports all major transceivers with matched turns ration and complete integration of specified termination

Design for 100base-tx transmission over UTP-5 cable

Operating TEMP. range:-40 to +85

Storage TEMP. range:-55 to +125

Primary OCL inductance: 350µH MIN. at 100KHz/0.1Vrms 8mA DC bias

Typical Performance Characteristics@ 25

Insertion Loss (dB MAX)	Return Loss (dB Min @100±15Ω)				Differential to Common Mode Rejection (dB MIN)	Cross talk (dB MIN)					CMRR (dB MIN)	Isolation Voltage (Vrms min)
	MHz	MHz				MHz	MHz					
1~100	1~30	40	50	60~80	1~100	20	40	60	80	100	1~100	1500
-1.0	-16	-14	-12	-10	-33	-47	-40	-37	-35	-33	-30	

Schematic: Design on MDI Interface Circuitry

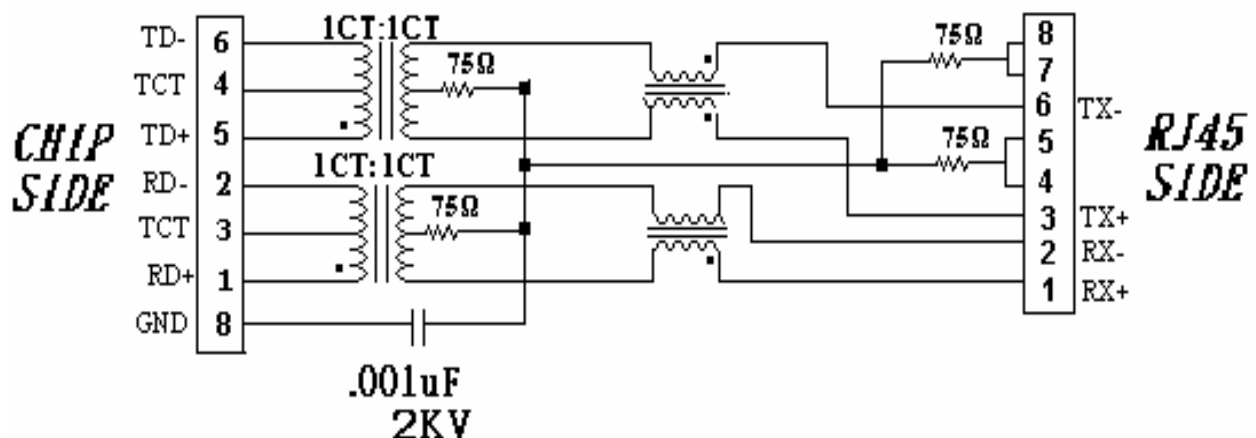

MODEL NO. : RJ-053TA1

Dimension: mm

TOLERANCE:±0.15 (unless otherwise specified)

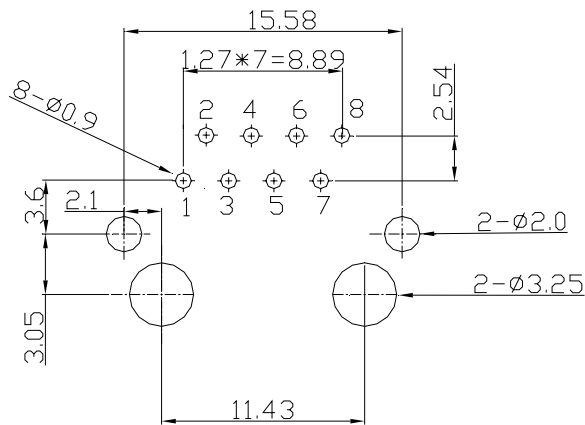
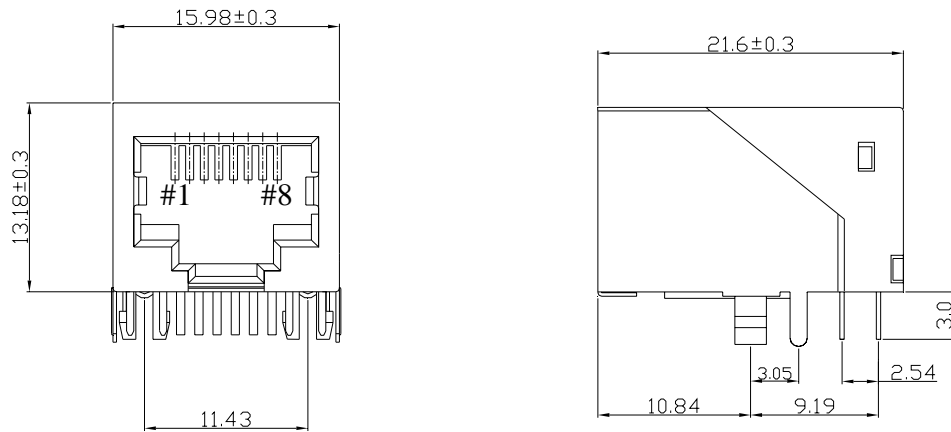

RECOMMENDED P.C.B LAYOUT
COMPONENT SIDE OF BOARD



NUMBER:RD-SDRJ-053TA1
DATE : 2005/09/09 I(REV:A1)

MODEL NO. : RJ-053TA1

Ordering Information

R J - 0 5 3 T A 1	
R J 4 5	S e r i e s N O .

Requirements :

1. Design and Construction

Product shall be of design, construction and physical dimensions specified on applicable product drawing.

2. Materials and Finish

A. Contact:

RJ Contact : Phosphor Bronze, Thickness=0.30mm

Finish : Contact Area : 6 μ "min. Gold over 50 μ "min. Nickel

RJ Joint Contact : Phosphor Bronze, Thickness=0.3mm

Finish : 80 μ "min. Sn over 50 μ "min. Nickel

B. Plastic Part :

(1) Set Housing : Thermoplastic, PBT, Black

UL FILE NO. : E107536

Manufacturer : SHIKONG SYNTHETIC FIBERS CORP.

Grade : E202G30BK

Flame Class : UL 94V-0

(2) Insert : Thermoplastic, PBT, Black

UL FILE NO. : E107536

Manufacturer : SHIKONG SYNTHETIC FIBERS CORP.

Grade : E202G30BK

Flame Class : UL 94V-0

(3) Spacer : Thermoplastic, PBT, Black

UL FILE NO. : E107536

Manufacturer : SHIKONG SYNTHETIC FIBERS CORP.



NUMBER:RD-SDRJ-053TA1
DATE : 2005/09/09 I(REV:A1)

MODEL NO. : RJ-053TA1

Grade : E202G30BK

Flame Class : UL 94V-0

C. Shield Material :

Cartridge t=0.25mm

10 μ"-20 μ" Thick Nickel over Brass.

3. Ratings

(1) Voltage rating : 125 VAC

(2) Current rating : 1.5A

Durability :

(1)1000 cycles with no function damage for RJ-45 . Abnormalities shall be present after the test.

(2)Low Level Contact Resistance : $\Delta R=30m\Omega$ maximum (final)

(3)The sample should be mounted in the tester and fully mated and unmated 500 times per hour at the rate of 25mm/min.EIA-364-09C.



NUMBER:RD-SDRJ-053TA1
DATE : 2005/09/09 I(REV:A1)

MODEL NO.: **RJ-053TA1**

1. Unit weight :5.7 grams
2. package : 100 pcs / tray / 0.61 kgms
3. Carton : 1000 pcs / 10 layers of tray
4. Gross weight : 6.6455 kgms

