

Single 10/100BASE-TX Filtered RJ45 Connector Module MODEL NO. : RJL-007LB1

Features

- ⊙ RoHS Compliant
- ⊙ Fully shielded magnetics protect data from internally generated digital noise
- ⊙ Reduces the overall length of the signal path for improved common mode performance
- ⊙ Implements full common mode termination scheme with used and unused twisted pairs
- ⊙ Meets IEEE802.3 Baseline Wander Compensation specification
- ⊙ Integrates high voltage capacitor to chassis ground
- ⊙ Supports all major transceivers with matched turns ration and complete integration of specified termination
- ⊙ Design for 100base-tx transmission over UTP-5 cable
- ⊙ Operating TEMP. range: -40°C to +85°C
- ⊙ Storage TEMP. range: -55°C to +125°C
- ⊙ Primary OCL inductance: 350μH MIN. at 100KHz/0.1Vrms with 8mA DC bias
- ⊙ With the LED lamp

Typical Performance Characteristics

Insertion Loss (dB MAX)	Return Loss (dB Min @100±15Ω)				Differential to Common Mode Rejection (dB MIN)	Cross talk (dB MIN)					CMRR (dB MIN)	Isolation Voltage (Vrms min)
	MHz	MHz				MHz	MHz					
1~100	1~30	40	50	60~80	1~100	20	40	60	80	100	1~100	1500
-1.0	-16	-14	-12	-10	-33	-47	-40	-37	-35	-33	-30	

Schematic : Design on MDI Interface Circuitry

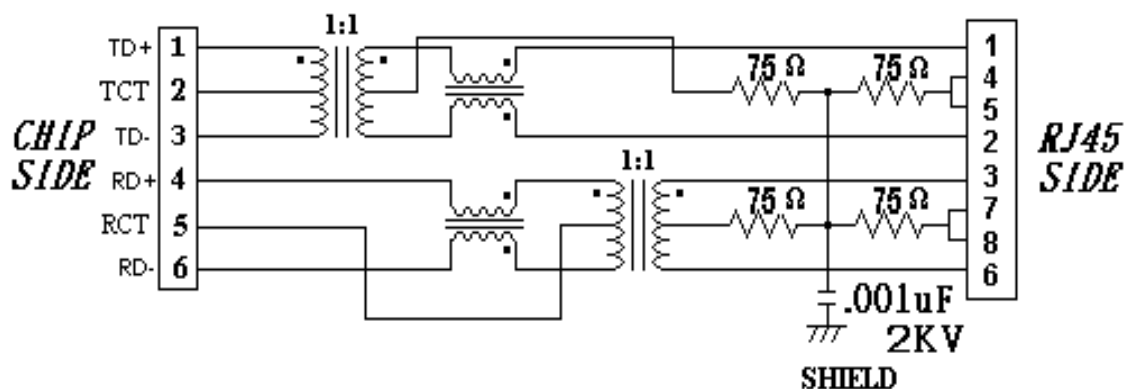

MODEL NO. : RJL-007LB1

Dimension: mm

TOLERANCE:±0.15 (unless otherwise specified)

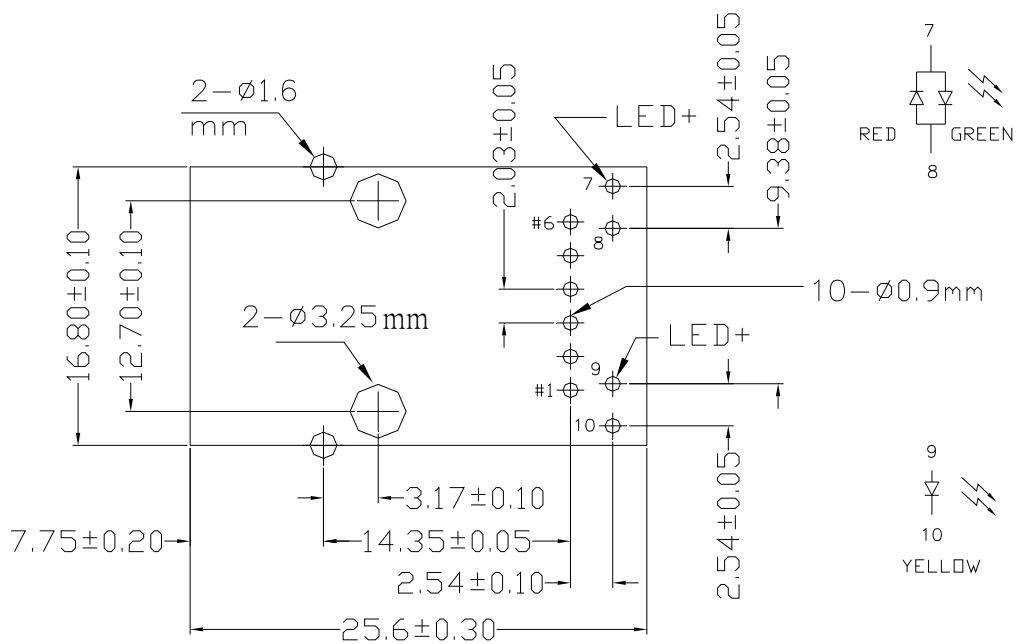
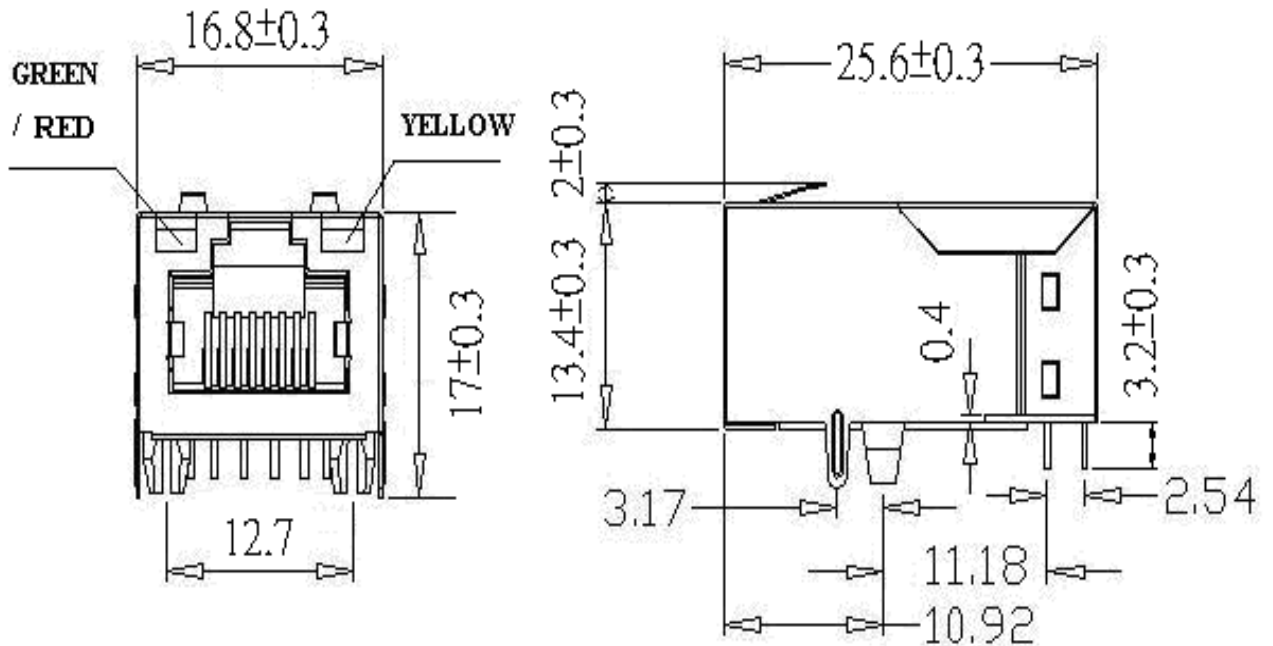

RECOMMENDED P.C.B LAYOUT
COMPONENT SIDE OF BOARD



NUMBER : RD-SDRJL-007LB1
DATE :2009/02/26 -R(REV:A1)

MODEL NO. : RJL-007LB1

Ordering Information

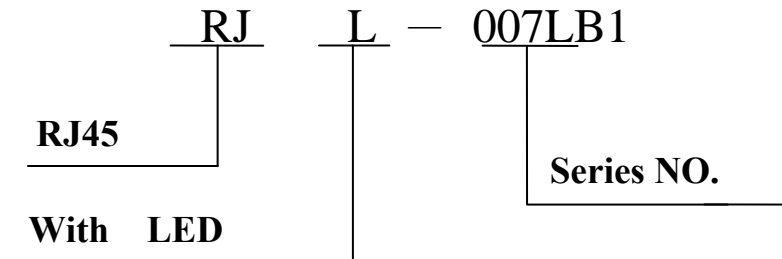

Requirements :

1. Design and Construction

Product shall be of design, construction and physical dimensions specified on applicable product drawing.

2. Materials and Finish

A. Contact:

RJ Contact : Phosphor Bronze, Thickness=0.30mm

Finish : Contact Area : 6 μ "min. Gold over 50 μ "min. Nickel

RJ Joint Contact : Brass, Thickness=0.4mm

Finish : 80 μ "min. Sn over 50 μ "min. Nickel

LED Joint Contact : Brass, Thickness=0.30mm

Finish : 80 μ "min. Sn over 50 μ "min. Nickel

B. Plastic Part :

(1) Set Housing : Thermoplastic, LCP, Black

UL FILE NO. : E83005

Manufacturer : POLYPLASTICS CO LTD.

Grade : E130i(+1)

Flame Class : UL 94V-0

(2) Insert : Thermoplastic, LCP, Black

UL FILE NO. : E83005

Manufacturer : POLYPLASTICS CO LTD.

Grade : E130i(+1)

Flame Class : UL 94V-0

(3) Spacer : Thermoplastic, LCP, Black

UL FILE NO. : E83005

Manufacturer : POLYPLASTICS CO LTD.

Grade : E130i(+1)

Flame Class : UL 94V-0



NUMBER : RD-SDR JL-007LB1
DATE :2009/02/26 -R(REV:A1)

MODEL NO. : R JL-007LB1

C. Shield Material :

Cartridge $t=0.25\pm 0.05\text{mm}$

10 μ "-20 μ " Thick Nickel over Brass

D. LED Lamp

(a) Lens Color : Transparent with color

(b) Emitted Color : Green / Red

(c) View Angle : 60°

(d) Wave Length : Green: 570nm / Red: 635nm

(e) Forward Current / Reverse Voltage :

Green 30 mA / (5V) ; Red 20 mA / (5V)

3. Ratings

(1)Voltage rating : 125 VAC

(2)Current rating : 1.5A

Durability :

(1)1000 cycles with no function damage for RJ-45 . Abnormalities shall be present after the test.

(2)Low Level Contact Resistance: $\Delta R=30\text{m}\Omega$ maximum (final)

(3)The sample should be mounted in the tester and fully mated and unmated 500 times per hour at the rate of 25mm/min.EIA-364-09C.

Model NO.: RJL-007LB1

1. Unit weight :7.9 grams
2. package : 50 pcs / tray / 0.435 kgms
3. Carton : 400 pcs / 8 layers of tray
4. Gross weight :4.025 kgms

Package drawing:

