

Single 10/100 BASE-TX Filtered Connector Module MODEL NO. : RJL12-001LC1

Features :

- ⊙ RoHS Compliant
- ⊙ Fully shielded magnetics protect data from internally generated digital noise
- ⊙ Reduces the overall length of the signal path for improved common mode performance
- ⊙ Implements full common mode termination scheme with used and unused twisted pairs
- ⊙ Meets IEEE802.3 Baseline Wander Compensation specification
- ⊙ Integrates high voltage capacitor to chassis ground
- ⊙ Supports all major transceivers with matched turns ration and complete integration of specified termination
- ⊙ Design for 100base-tx transmission over UTP-5 cable
- ⊙ Operating TEMP. range: -40°C to +85°C
- ⊙ Storage TEMP. range: -55°C to + 125°C
- ⊙ Primary OCL inductance: 350μH MIN. at 100KHz/0.1Vrms with 8mA DC bias.

Typical Performance Characteristics

Insertion Loss (dB MAX)	Return Loss (dB Min @100±15Ω)				Differential to Common Mode Rejection (dB MIN)	Cross talk (dB MIN)					CMRR (dB MIN)	Isolation Voltage (Vrms min)
MHz	MHz				MHz	MHz					MHz	1500
1~100	1~30	40	50	60~80	1~100	20	40	60	80	100	1~100	
-1.1	-16	-14	-12	-10	-33	-47	-40	-37	-35	-33	-30	

Schematic: Design on MDI Interface Circuitry

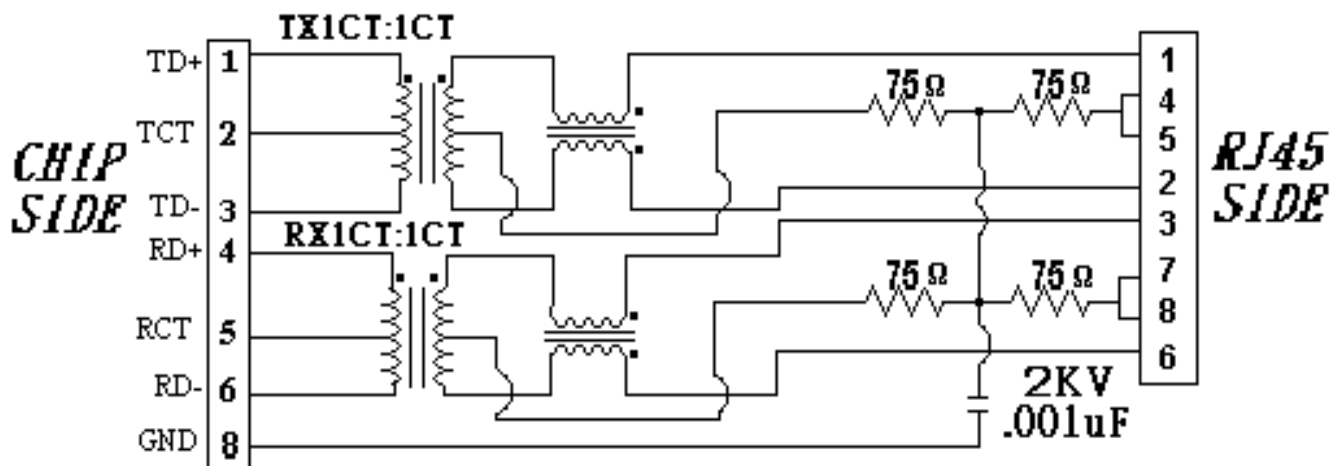

MODEL NO. : RJL12-001LC1

Dimension: mm

TOLERANCE:±0.15 (Unless otherwise specified)

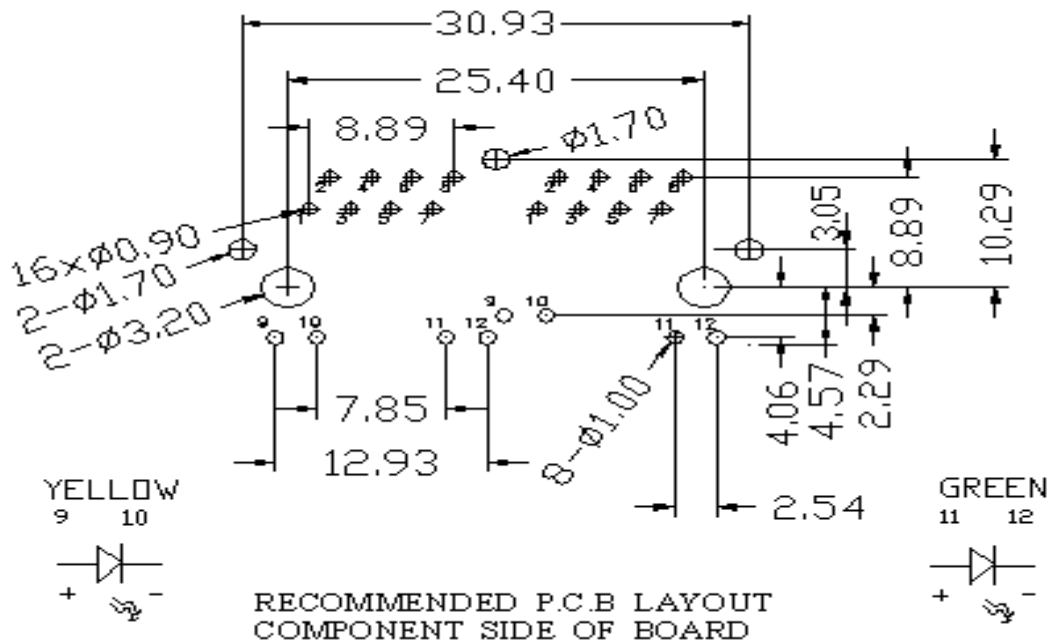
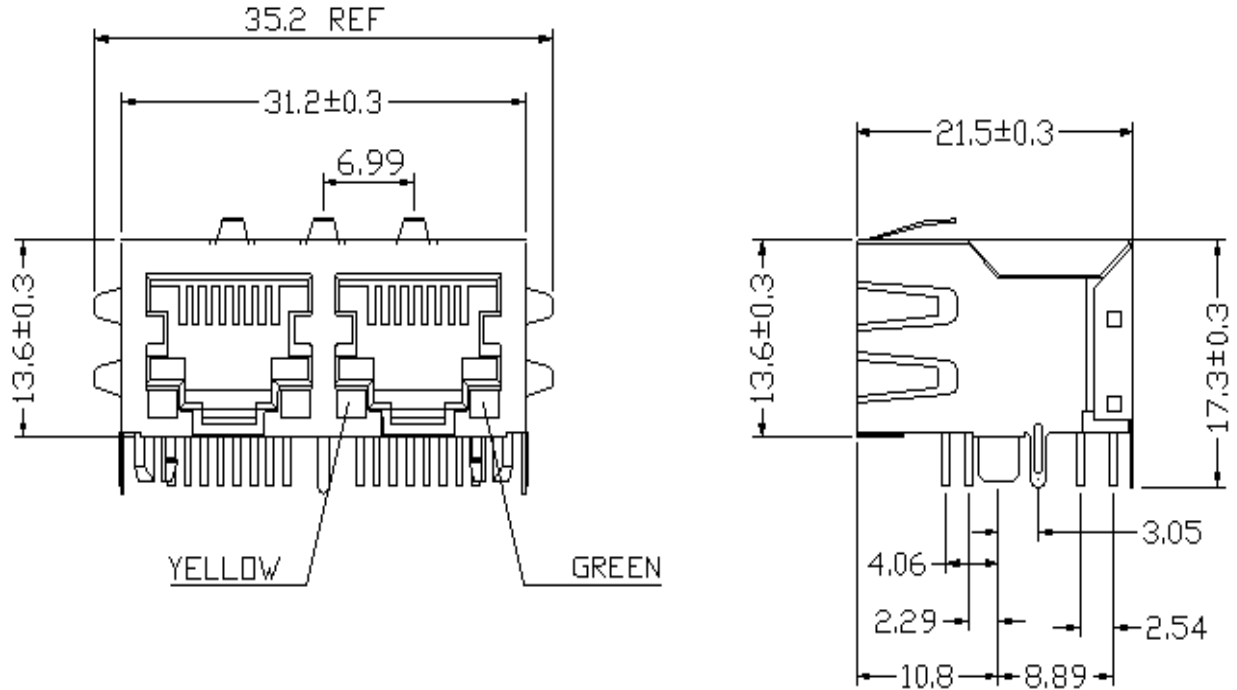



NUMBER:RD-SD-RJL12-001LC1

DATE :2009/02/18-R (REV:A1)

MODEL NO. : RJL12-001LC1

Ordering Information

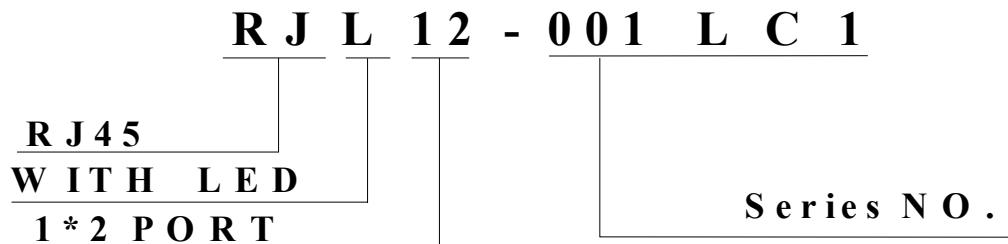

Requirements :

1. Design and Construction

Product shall be of design, construction and physical dimensions specified on applicable product drawing.

2. Materials and Finish

A. Contact:

RJ Contact : Phosphor Bronze, Thickness=0.35mm

Finish : Contact Area :6 μ "min. Gold over 50 μ "min. Nickel

RJ Joint Contact : Brass, Thickness=0.30mm

Finish : 80 μ "min. Sn over 50 μ "min. Nickel

LED Joint Contact : SPCC, Thickness=0.50mm

Finish : 80 μ "min. Sn over 50 μ "min. Nickel

B. Plastic Part :

(1) Set Housing : Thermoplastic, LCP, Black

UL FILE NO. : E106764

Manufacturer : POLYPLASTICS CO LTD.

Grade : E130i(d)(e)

Flame Class : UL 94V-0

(2) Insert : Thermoplastic, LCP, Black

UL FILE NO. : E106764

Manufacturer : POLYPLASTICS CO LTD.

Grade : E130i(d)(e)

Flame Class : UL 94V-0

(3) Spacer : Thermoplastic, LCP, Black

UL FILE NO. : E106764

Manufacturer : POLYPLASTICS CO LTD.

Grade : E130i(d)(e)

Flame Class : UL 94V-0



NUMBER:RD-SD-RJL12-001LC1

DATE :2009/02/18-R (REV:A1)

MODEL NO. : RJL12-001LC1

C. Shield Material :

Cartridge $t=0.25\pm 0.05$ mm

30 μ "MIN Thick Nickel over Brass

D. LED Lamp

(a) Lens Color : Transparent with color

(b) Emitted Color : Green & Yellow

(c) View Angle : 65°

(d) Wave Length : Green 565nm ; Yellow 585nm

(e) Recommended operation current (IF) : 20 mA

Durability :

- (1) 1000 cycles with no function damage for RJ-45 . Abnormalities shall be present after the test.**
- (2) Low Level Contact Resistance : $\Delta R=30m\Omega$ maximum (final).**
- (3) The sample should be mounted in the tester and fully mated and unmated 500 times per hour at the rate of 25mm/min. EIA-364-09C.**