

10/100 BASE FILTER WITH CONNECTOR

MODEL NO. : RJLB-054TA1

Feature:

- ◎ RoHS Compliant
- ◎ Fully shielded magnetic protect data from internally generated digital noise
- ◎ Reduces the overall length of the signal path for improved common mode performance
- ◎ Implements full common mode termination scheme with used and unused twisted pairs
- ◎ Meets IEEE802.3 Baseline Wander Compensation specification
- ◎ Integrates high voltage capacitor to chassis ground
- ◎ Supports all major transceivers with matched turns ration and complete integration of specified termination
- ◎ Design for 100base-tx transmission over UTP-5 cable
- ◎ Operating TEMP. range: -40 to +85
- ◎ Storage TEMP. range: -55 to + 125
- ◎ Primary OCL inductance: 350 μ H MIN. at 100KHz/0.1Vrms with 8mA DC bias
- ◎ With the LED lamp.

Typical Performance Characteristics@ 25

Insertion Loss (dB MAX)	Return Loss (dB Min @100 \pm 15 Ω)				Differential to Common Mode Rejection (dB MIN)	Cross talk (dB MIN)					CMRR (dB MIN)	Isolation Voltage (Vrms min)
	MHz	MHz				MHz						
1~100	1~30	40	50	60~80	1~100	20	40	60	80	100	1~100	
-1.0	-16	-14	-12	-10	-33	-47	-40	-37	-35	-33	-30	

Schematic: Design on MDI Interface Circuitry

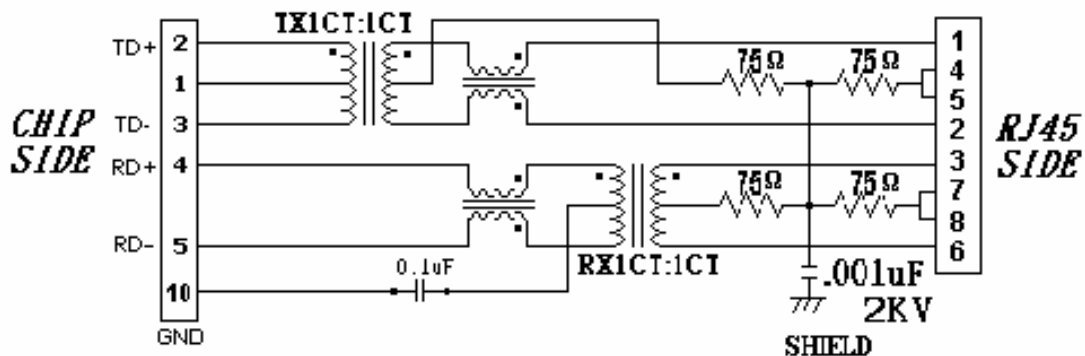

MODEL NO. : RJLB-054TA1

Dimension: mm

TOLERANCE: ±0.15 (Unless otherwise specified)

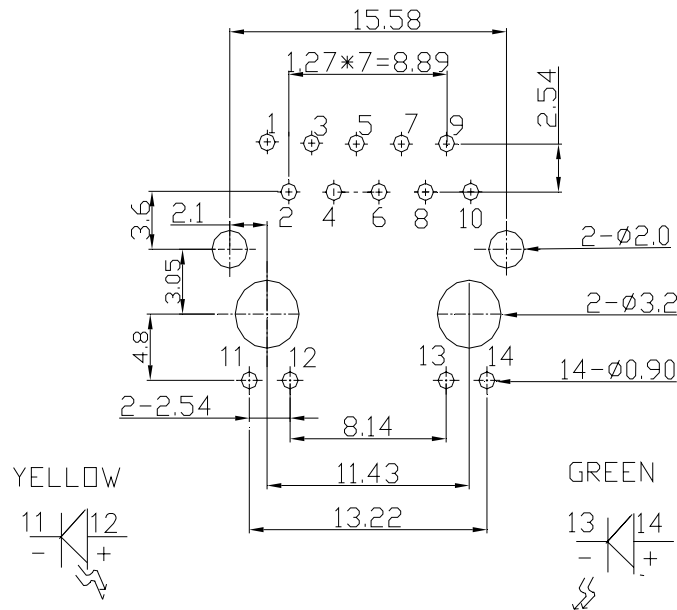
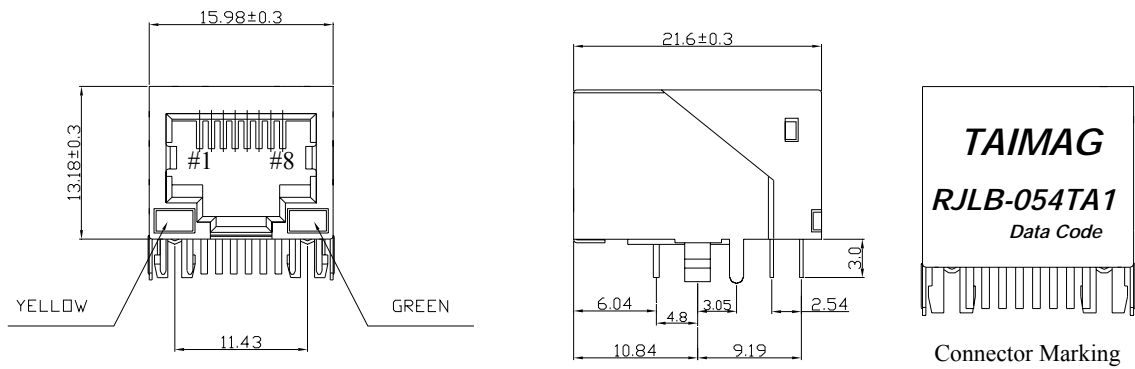

**RECOMMENDED P.C.B LAYOUT
COMPONENT SIDE OF BOARD**



NUMBER:RD-RJ-RJLB-054TA1
DATE : 2005/09/09 I(REV:A1)

MODEL NO. : RJLB-054TA1

Ordering Information

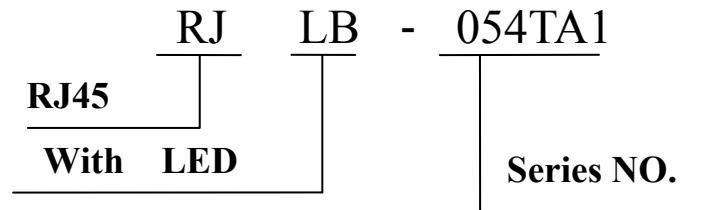

Requirements :

1. Design and Construction

Product shall be of design, construction and physical dimensions specified on applicable product drawing.

2. Materials and Finish

A. Contact:

RJ Contact : Phosphor Bronze, Thickness=0.30mm

Finish :Contact Area : 6 μ "min. Gold over 50 μ "min. Nickel

RJ Joint Contact : Brass, Thickness=0.30mm

Finish : 80 μ "min. Sn over 50 μ "min. Nickel

LED Joint Contact : Brass, Thickness=0.50mm

Finish : 80 μ "min. Sn over 50 μ "min. Nickel

B. Plastic Part :

(1) Set Housing : Thermoplastic, PBT, Black

UL FILE NO. : E107536

Manufacturer : SHIKONG SYNTHETIC FIBERS CORP.

Grade : E202G30BK

Flame Class : UL 94V-0

(2) Insert : Thermoplastic, PBT, Black

UL FILE NO. : E107536

Manufacturer : SHIKONG SYNTHETIC FIBERS CORP.

Grade : E202G30BK

Flame Class : UL 94V-0

(3) Spacer : Thermoplastic, PBT, Black

UL FILE NO. : E107536



NUMBER:RD-RJ-RJLB-054TA1
DATE : 2005/09/09 I(REV:A1)

MODEL NO. : RJLB-054TA1

Manufacturer : SHIKONG SYNTHETIC FIBERS CORP.

Grade : E202G30BK

Flame Class : UL 94V-0

C. Shield Material :

Cartridge t=0.25mm

10 μ"-20 μ" Thick Nickel over Brass.

D. LED Lamp

(a) Lens Color : Transparent with color

(b) Emitted Color : Yellow & Green

(c) View Angle : 65°

(d) Wave Length : Yellow 585nm ; Green 565nm

(e) Recommended operation current (IF) : 20 mA

3. Ratings

(1) Voltage rating : 125 VAC

(2) Current rating : 1.5A

Durability :

(1) 1000 cycles with no function damage for RJ-45 . Abnormalities shall be present after the test.

(2) Low Level Contact Resistance : $\Delta R=30m\Omega$ maximum (final)

(3) The sample should be mounted in the tester and fully mated and unmated 500 times per hour at the rate of 25mm/min.EIA-364-09C.



NUMBER:RD-RJ-RJLB-054TA1
DATE : 2005/09/09 I(REV:A1)

Model NO.: RJLB-054TA1

1. Unit weight :5.7 grams
2. package : 100 pcs / tray / 0.61 kgms
3. Carton : 1000 pcs / 10 layers of tray
4. Gross weight : 6.6455 kgms

Package drawing:

