

10/100/1000 BASE FILTER WITH DUAL USB 2.0 CONNECTOR Model: RJLUG-012TC1

Feature:

☉ RoHS Compliant

- Fully shielded magnetics protect data from internally generated digital noise
- Reduces the overall length of the signal path for improved common mode performance
- Implements full common mode termination scheme with used and unused twisted pairs
- Meets IEEE802.3 Baseline Wander Compensation specification
- Integrates high voltage capacitor to chassis ground
- Supports all major transceivers with matched turns ration and complete integration of specified termination
- Design for 1000BASE-tx transmission over UTP-5 cable.
- Operating TEMP. range: -40 to +85
- Storage TEMP. range: -55 to + 125
- Primary OCL inductance: 350uH MIN. at 100KHz/0.1Vrms with 8mA DC bias.
- With the LED lamp.

Typical Performance Characteristics

Insertion Loss (dB MAX)	Return Loss (dB Min @100±15Ω)				Differential to Common Mode Rejection (dB MIN)	Cross talk (dB MIN)					CMRR (dB MIN)	Isolation Voltage (Vrms min)
	MHz	MHz				MHz	MHz					
1~100	1~30	40	50	60~80	1~100	20	40	60	80	100	1~100	1500
-1.0	-16	-14	-12	-10	-33	-47	-40	-37	-35	-33	-30	

Schematic Design on MDI Interface Circuitry

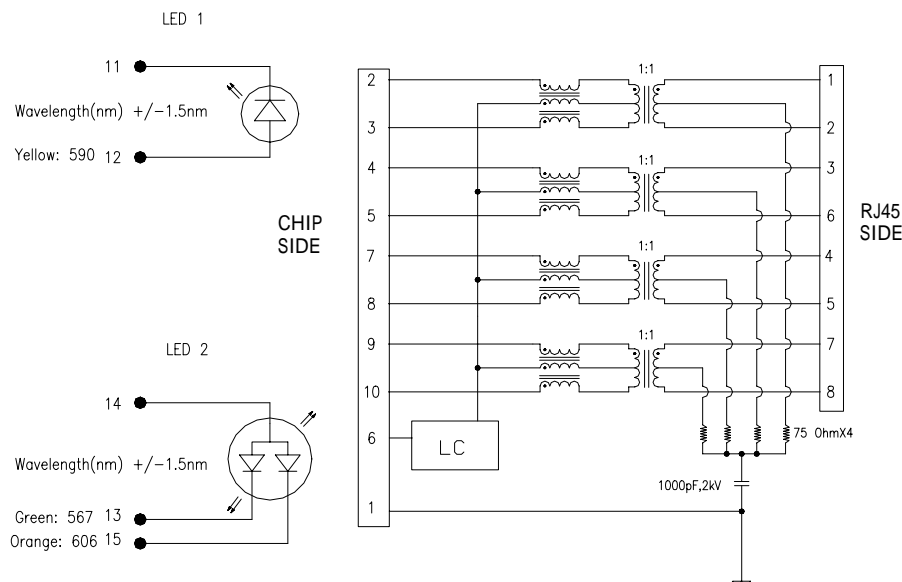



NUMBER:RD-SDRJLUG-012TC1
DATE : 2005/10/25 -C (REV:A1)

Model: RJLUG-012TC1

Dimension: mm

TOLERANCE:±0.15 (Unless otherwise specified)

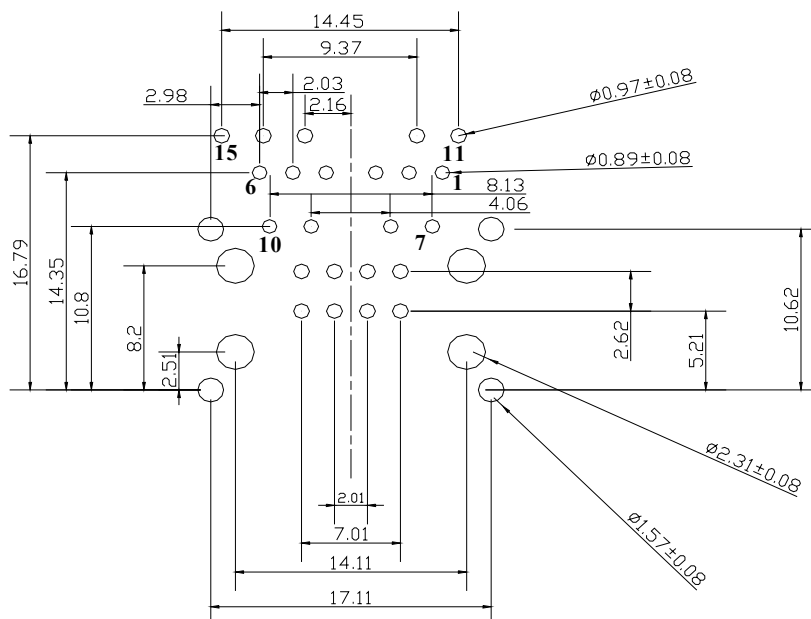
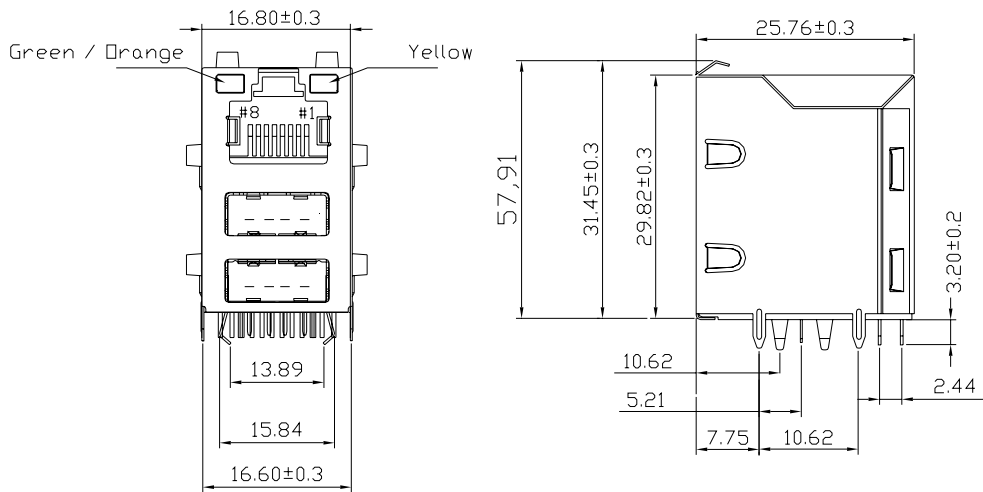
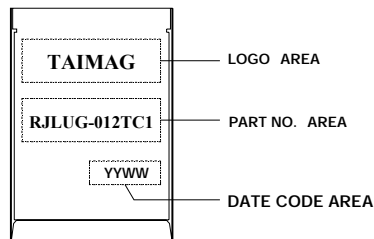



Model: RJLUG-012TC1

Ordering Information

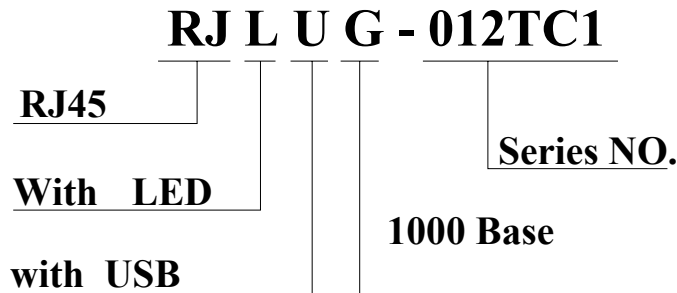

Requirements :

1. Design and Construction

Product shall be of design, construction and physical dimensions specified on applicable product drawing.

2. Materials and Finish

A. Contact:

RJ Contact : Phosphor Bronze, Thickness=0.35mm

Finish : Contact Area : 6 μ "min. Gold over 50 μ "min. Nickel

RJ Joint Contact : Brass, Thickness=0.40mm

Finish : 80 μ "min. Sn over 50 μ "min. Nickel

USB Contact : Phosphor Bronze, Thickness=0.25mm

Finish : Contact Area : 30 μ "min. Gold over 50 μ "min. Nickel

LED Joint Contact : Brass, Thickness=0.40mm

Finish : 80 μ "min. Sn over 50 μ "min. Nickel

B. Plastic Part :

(1) Set Housing : Thermoplastic, PBT, Black

UL FILE NO. : E107536

Manufacturer : SHIKONG SYNTHETIC FIBERS CORP.

Grade : E202G30BK

Flame Class : UL 94V-0

(2) Insert : Thermoplastic, PBT, Black

UL FILE NO. : E107536

Manufacturer : SHIKONG SYNTHETIC FIBERS CORP.

Grade : E202G30BK

Flame Class : UL 94V-0



NUMBER:RD-SDRJLUG-012TC1
DATE : 2005/10/25 -C (REV:A1)

MODEL NO. : RJLUG-012TC1

(3) Spacer : Thermoplastic, PBT, Black

UL FILE NO. : E107536

Manufacturer : SHIKONG SYNTHETIC FIBERS CORP.

Grade : E202G30BK

Flame Class : UL 94V-0

(4) USB Housing : Thermoplastic, PBT, Black

UL FILE NO. : E107536

Manufacturer : SHIKONG SYNTHETIC FIBERS CORP.

Grade : E202G30BK

Flame Class : UL 94V-0

C. Shield Material :

Cartridge $t=0.25\text{mm}$

10 μ ”-20 μ ” Thick Nickel over Brass

D. LED Lamp

(a) Lens Color : Transparent with color

(b) Emitted Color : Green, Orange & Yellow

(c) View Angle : 65°

(d) Wave Length : Green 565nm ; Orange 610nm ; Yellow 585nm

(e) Recommended operation current (IF) : 20 mA

3. Ratings

(1) Voltage rating : 125 VAC

(2) Current rating : 1.5A

Durability :

1000 cycles with no function damage for RJ-45 . Abnormalities shall be present after the test.

Low Level Contact Resistance : $\Delta R=30\text{m}\Omega$ maximum (final)

The sample should be mounted in the tester and fully mated and unmated 500 times per hour at the rate of 25mm/min. EIA-364-09C.



NUMBER:RD-SDRJLUG-012TC1
DATE : 2005/10/25 -C (REV:A1)

MODEL NO. : RJLUG-012TC1

1. Unit weight :20.6 grams
2. package : 50 pcs / tray / 1.044 kgms
3. Carton : 400 pcs / 8 layers of tray
4. Gross weight : 8.964 kgms

Package drawing:

