

10/100/1000 BASE FILTER WITH DUAL USB 2.0 CONNECTOR Model NO.: RJLUG-028TA1

Feature:

RoHS Compliant

- ⊙ Fully shielded magnetic protect data from internally generated digital noise
- ⊙ Reduces the overall length of the signal path for improved common mode performance
- ⊙ Implements full common mode termination scheme with used and unused twisted pairs
- ⊙ Meets IEEE802.3 Baseline Wander Compensation specification
- ⊙ Integrates high voltage capacitor to chassis ground
- ⊙ Supports all major transceivers with matched turns ration and complete integration of specified termination
- ⊙ Design for 1000BASE-tx transmission over UTP-5 cable.
- ⊙ Operating TEMP. range: -40°C to +85°C
- ⊙ Storage TEMP. range: -55°C to + 125°C
- ⊙ Primary OCL inductance: 350uH MIN. at 100KHz/0.1Vrms with 8mA DC bias.
- ⊙ With the LED lamp.

Typical Performance Characteristics@ 25C

| Insertion Loss (dB MAX) | Return Loss (dB Min @100±15Ω) | | | | Differential to Common Mode Rejection (dB MIN) | Cross talk (dB MIN) | | | | | CMRR (dB MIN) | Isolation Voltage (Vrms min) |
|----------------------------|----------------------------------|-----|-----|-------|---|------------------------|-----|-----|-----|-----|------------------|------------------------------------|
| MHz | MHz | | | | MHz | MHz | | | | | MHz | 1500 |
| 1~100 | 1~30 | 40 | 50 | 60~80 | 1~100 | 20 | 40 | 60 | 80 | 100 | 1~100 | |
| -1.0 | -16 | -14 | -12 | -10 | -33 | -47 | -40 | -37 | -35 | -33 | -30 | |

Schematic Design on MDI Interface Circuitry

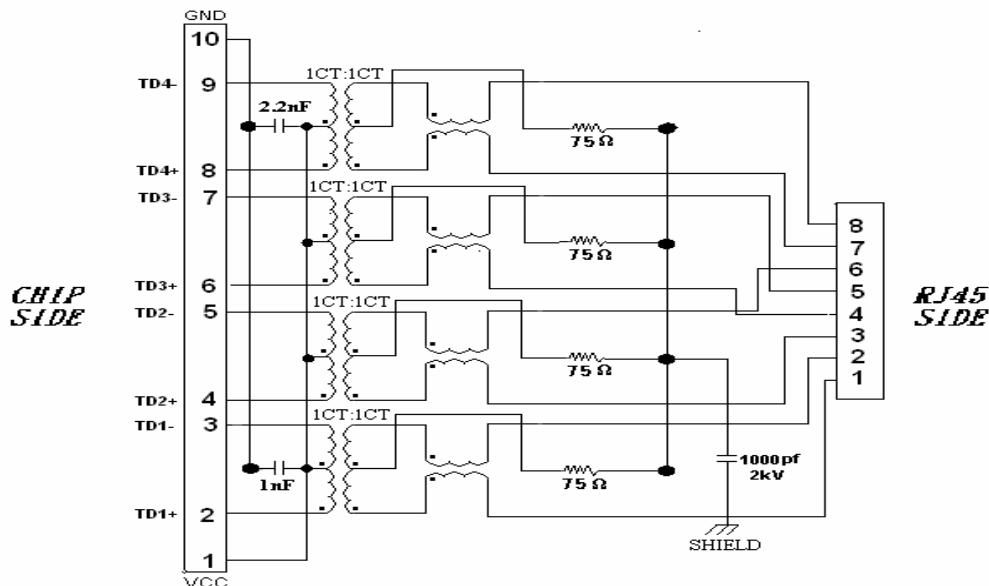



NUMBER:RD-RJ-RJLUG-028TA1
DATE : 2005/09/08-I(REV:A1)

Model NO.: RJLUG-028TA1

Ordering Information

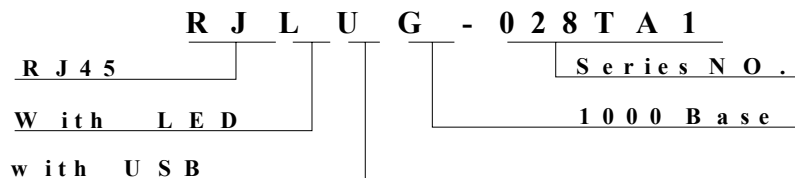

Requirements :

1. Design and Construction

Product shall be of design, construction and physical dimensions specified on applicable product drawing.

2. Materials and Finish

A. Contact:

RJ Contact : Phosphor Bronze, Thickness=0.30mm

Finish : (a) Contact Area : 6 μ "min. Gold over 50 μ "min. Nickel

RJ Joint Contact : Brass, Thickness=0.30mm

Finish : 80 μ "min. Sn over 50 μ "min. Nickel

USB Contact : Phosphor Bronze, Thickness=0.25mm

Finish : (a) Contact Area : 30 μ "min. Gold over 50 μ "min. Nickel

LED Joint Contact : Brass, Thickness=0.30mm

Finish : 80 μ "min. Sn over 50 μ "min. Nickel

B. Plastic Part :

(1) Set Housing : Thermoplastic, PBT, Black

UL FILE NO. : E107536

Manufacturer : SHIKONG SYNTHETIC FIBERS CORP.

Grade : E202G30BK

Flame Class : UL 94V-0

(2) Insert : Thermoplastic, PBT, Black

UL FILE NO. : E107536

Manufacturer : SHIKONG SYNTHETIC FIBERS CORP.

Grade : E202G30BK

Flame Class : UL 94V-0



NUMBER:RD-RJ-RJLUG-028TA1
DATE : 2005/09/08-I(REV:A1)

Model NO.: RJLUG-028TA1

(3) Spacer : Thermoplastic, PBT, Black

UL FILE NO. : E107536

Manufacturer : SHIKONG SYNTHETIC FIBERS CORP.

Grade : E202G30BK

Flame Class : UL 94V-0

(4) USB Housing : Thermoplastic, PBT, Black

UL FILE NO. : E107536

Manufacturer : SHIKONG SYNTHETIC FIBERS CORP.

Grade : E202G30BK

Flame Class : UL 94V-0

C. Shield Material :

Cartridge $t=0.25\text{mm}$

$10\ \mu\text{''}$ - $20\ \mu\text{''}$ Thick Nickel over Brass

D. LED Lamp

(a) Lens Color : Transparent with color

(b) Emitted Color : Green, Yellow

(c) View Angle : 65°

(d) Wave Length : Green 565nm ; Yellow 585nm

(e) Recommended operation current (IF) : 20 mA

3. Ratings

(1) Voltage rating : 125 VAC

(2) Current rating : 1.5A

Durability :

1000 cycles with no function damage for RJ-45 . Abnormalities shall be present after the test.

Low Level Contact Resistance : $\Delta R=30\text{m}\Omega$ maximum (final)

The sample should be mounted in the tester and fully mated and unmated 500 times per hour at the rate of 25mm/min. EIA-364-09C.



NUMBER:RD-RJ-RJLUG-028TA1
DATE : 2005/09/08-I(REV:A1)

Model NO.: RJLUG-028TA1

1. Unit weight :20.6 grams
2. package : 50 pcs / tray / 1.044 kgms
3. Carton : 400 pcs / 8 layers of tray
4. Gross weight : 8.964 kgms

Package drawing:

